

- a strong solution for the environment

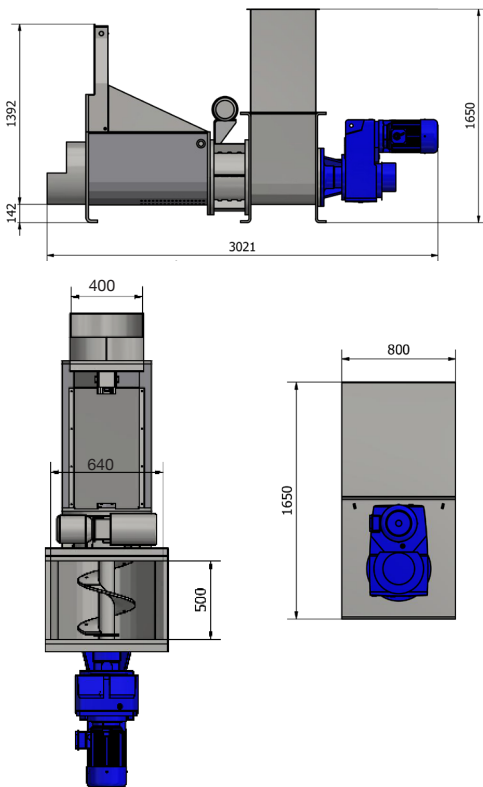
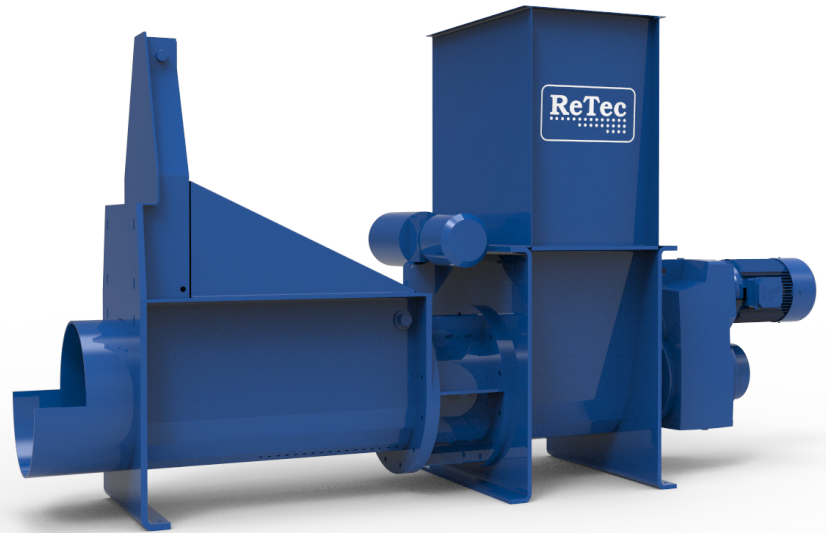

RETEC DEWATERING SCREW

The purpose of the dewatering system is to compress and drain the packaging.

Input: e.g. PET bottles, Tetra Pak, metal cans etc.

The material is filled into the hopper and down to the screw. The packaging is lead into the pressing channel, where the packaging is compressed and dewatered.

Output: Compressed and dewatered packaging

Capacity: up to 10m³/h (depending on material)

Specifications:

- Type: RAP 400
- 7,5 kW gearmotor (Nord-gear)
- RPM approx. 12
- Screw d=370 mm with welded carbide at the press surface
- Hydraulic press jaw, full automatic
- Input opening 500 x 640 mm
- Outlet: d=400 mm
- Volume reduction: approx. 7-9:1

- Collection tray for dewatered liquid
- Weight approx. 1.000 kg
- Manual and documentation according to the Machinery Directive

Options:

- Chute to container
- Specialized hopper
- Automatic start and stop



ReTec Miljø ApS
Fjordagervej 38
DK-6100 Haderslev

Tel.: +45 7456 8106
Fax: +45 7456 8581
VAT: DK 25 86 24 22

sales@retec.dk
www.retec.dk

ReTec develops, constructs and manufactures special machines for the waste and recycling industry. We offer practical solutions to our customer's needs, helping them increase profitability in their business.